

Testimonials

"We used the Commercial Event on the Eclipse Development site at The Pinjarra Railway Station (see front cover). The product was chosen because it is a quiet and effective ventilation system that has not moving parts and is discrete on the roof. E-Vent™ is especially effective in areas that are wind affected as there is no noise and risk of damage." Alan Woodbury, AI the Roofer

"We had E-Vent™ installed on the City Farmers Warehouse two years ago. The product has made considerable difference to the temperature in the building, particularly in summer. Previously, the summer months were quite uncomfortable in the warehouse, but the E-vent™ has reduced temperatures quite considerably." Peter Nicotri, City Farmers, Caversham



e-vent™

environmental venting solution

Your hassle-free industrial venting solution.

Call Combined Metal Industries on 1800 651 303 for enquiries about E-vent™.

When you call, ask us to send you a copy of our free E-vent™ Custom Design Calculator CD-ROM. This software makes calculating E-vent™ specifications and costings for your next project quick and simple.

E-vent™ is manufactured by Combined Metal Industries to ISO 9002 standards
E-vent™ Patent No. 673749

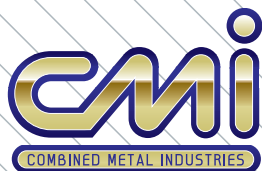

Colorbond®

17-23 Hoskins Road
Landsdale WA 6065

PO Box 1073
Wangara WA 6947

Telephone: (08) 9309 1303
Facsimile: (08) 9309 1684

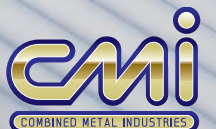

Your hassle-free industrial venting solution

E-vent™ is a highly effective, environmentally friendly venting solution for industrial buildings. Manufactured by Combined Metal Industries, the Industrial E-vent™ finally provides specifiers and builders with a quick, convenient and hassle free solution for both ridge and slope industrial venting.



“CMI has both the technology and infrastructure to produce a quality venting solution without any outsourcing of production”

WHAT IS E-VENT™?

E-vent™ is a new natural ventilation system for industrial buildings with metal roofing. Available in both ridge and slope vents, E-vent™ naturally exhausts hot air and noxious gases from industrial and commercial buildings through an innovative design.

E-vent™'s design harnesses the combined natural forces of different air pressure (Venturi effect) and convection (Stack effect). Designed to overcome the frustrations with existing ventilation systems on the market. E-vent™ has been found to be highly effective, efficient and environmentally friendly venting solution (hence the “E” in E-vent™).

WHAT IS E-VENT™?

The Industrial E-vent™ is available as both Ridge and Slope Vents.

As a fully assembled unit, the E-vent™ can have up to a 300mm throat. If a wider throat is required, the E-vent™ can be assembled on site with a throat of up to 450mm. Unassembled E-vents™ are delivered to site as components and come with full and detailed fixing instructions. Special size E-Vents™ (greater than 450mm throat) can also be manufactured if required.

Full details of E-vent™ technical information are found in our easy to use E-vent™ Custom Design Calculator CD-ROM. CMI's interactive E-vent™ CD-ROM gives you more than just technical data, it allows you to drop in your project's measurement so that you can quickly identify and order the E-vent™ that meets your project's design needs. If you don't already have the E-vent™ CD-ROM, please call CMI on 9309 1303.

HOW DOES E-VENT™ BENEFIT YOUR CLIENT'S BUILDING

- **E-vent™ operates efficiently to significantly reduce heat indoors** – E-vent™ uses the twin powers of Venturi and Stack Effects to effectively exhaust hot air and noxious gases. This innovative but simple design even operates efficiently in light winds providing that appropriate inlet ventilation has also been installed.
- **E-vent™ can be manufactured and delivered within short timeframes** – as a result of CMI's computerized manufacturing equipment and production technology, E-vent™ production and delivery time is significantly faster than comparable products in the market. When CMI's fast turnarounds on orders is combined with advance planning, buildings can even have their vents installed at the same time as the roof. This can result in major savings in both cost and project completion time, as only one visit is required by the roofing contractor.

- **E-Vents™ are convenient and hassle-free to design and order** – the E-vent™ Custom Design Calculator CD-ROM makes calculating your venting requirements and measurements a quick and simple process. Specifying and ordering becomes an easy task as all the technical data and information you need on designing and purchasing E-Vents™ is a click or two away. Service and technical advice is also on hand at CMI with expert staff available to help you with your enquiries.

- **E-vents™ are competitively priced** – due to the production efficiencies and buying power of Combined Metal Industries, E-Vents™ are extremely competitive in price. Take the time with your next project to check out any one of CMI's range of industrial E-Vents™ and you'll be pleasantly surprised that E-Vent™'s quality and turnaround time doesn't mean you have to pay a higher price.

- **Event is a quality venting product that lasts** – all components of E-vent™ are built in-house by CMI, ensuring quality control is kept to a maximum. CMI's total commitment to the roofing industry means CMI has both the technology and infrastructure to produce a quality venting solution without any outsourcing of production. As a quality assured company, CMI is 9001-2000 accredited and E-vent™ benefits from the same process of quality production and control. E-vent™ can be purchased in a wide range of Bluescope Steel materials, including Colorbond™ Steel and Zinalume. Also available in galvanized, stainless steel and aluminium.

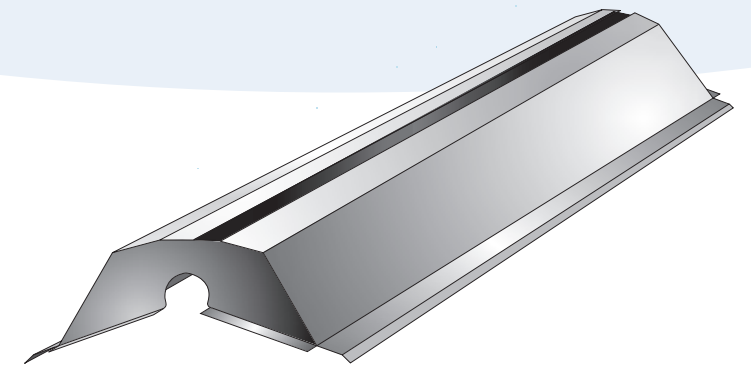

- E-vent™ enjoys an innovative, low profile design – the E-vent™ has been designed in a simple yet innovative way that makes it extremely easy to assemble. One of the objectives of its simplicity was to reduce time and labour costs when on site assembly is required. E-vent™'s low profile design is also aesthetically pleasing, and while this is not that important in an industrial setting, it is still a feature to consider in a building's appearance.

HOW DOES E-VENT™ WORK?

Using principles first expounded by Bernoulli and Venturi in the 18th century, the architect designed E-vent™ is a completely natural and environmental ventilating system. Bernoulli propounded that the pressure of a moving body of air or water is least where the velocity of the mass is greatest. In simple terms, by accelerating an air flow across a given surface or opening, a pressure differential can be created to produce a natural force and that harnessed force can produce power. It is applied in aircraft flight and venturi systems generally.

E-vent™ harness this natural power by creating low pressure areas on the upper and downwind sides of the vents creating a natural and effective exhausting air pump. That in turn means that air at normal pressure within a building will be literally sucked out by wind flow. And on the stillest of days, E-Vents™ still work by reason of simple convection or 'stack effect'.

OTHER APPLICATIONS

- ridge vent
- sloped roof skylights
- flat roof skylights
- vents for wet areas such as bathrooms, kitchens or toilets
- fire warning vents

OTHER BENEFITS

- easy to install/assemble
- cost-free operation
- early smoke detection
- condensation management
- leaf and vermin proof
- rain draining
- satisfies all building laws
- tailor made to each installation
- rust resistant materials

■ Warm air rises due to stack effect

■ Wind accelerates across E-vent™ opening, extracting warm roof space air due to venturi effect

